

CR12X series cylindrical capacitive sensor



Feature description

- One-piece housing with high-brightness LED indicator
- IP67 protection class which is effectively moisture-proof and dust-proof
- Enhance detection distance. Sensitivity adjustment adopts multi-turn potentiometer so as to reach higher adjustment accuracy
- High reliability, excellent EMC design with protection against short circuit, overloaded and reverse polarity
- Widely used in both metal and non-metal (plastic, powder, liquid, etc.) material testing



Model specification

NPN NO	CR12XCN08DNOY	PNP NO	CR12XCN08DPOY
NPN NC	CR12XCN08DNCY	PNP NC	CR12XCN08DPCY

Specifications

Installation type	Non-flush	Indicator	Output indication:Yellow LED
Rated distance S_n	8mm ^①	Switching frequency	25Hz
Ensure distance S_a	≤5.76mm	Ambient temperature	When working:-25...70°C(No icing, No condensation)
Adjust the distance	3...12mm		When storing:-30...80°C(No icing, No condensation)
Adjustment method	Single-turn potentiometer	Environment humidity	35...95%RH(No icing, No condensation)
Standard test object	Fe 24*24*1t(Grounded) ^②	Vibration resistant	10...55Hz,Dual amplitude 1mm(2 hours each in X, Y, and Z directions)
Supply voltage	10...30VDC	Impulse withstand	30g/11ms,3 times each for X,Y,Z direction
Load current	≤200mA	High pressure resistant	1000V/AC 50/60Hz 60s
Residual voltage	≤2V	Insulation resistance	≥50MΩ(500VDC)
Consumption current	≤20mA	Shape specification	M12*1*68mm
Switch point offset [%/Sn]	≤±10%	Protection degree	IP67
Temperature drift [%/Sr]	≤±20%	Housing material	Nickel copper alloy
Hysteresis range [%/Sr]	3...20%	Connection type	2m PVC Cable
Repetitive error [R]	≤5%	Accessories	M12 nuts×2, Slotted screwdriver, Operation manual
Circuit protection	Short circuit protection, Overload protection, Reverse polarity protection		

Note: ①the factory default sensing distance is $S_n \pm 10\%$

②unit:mm

Dimensions

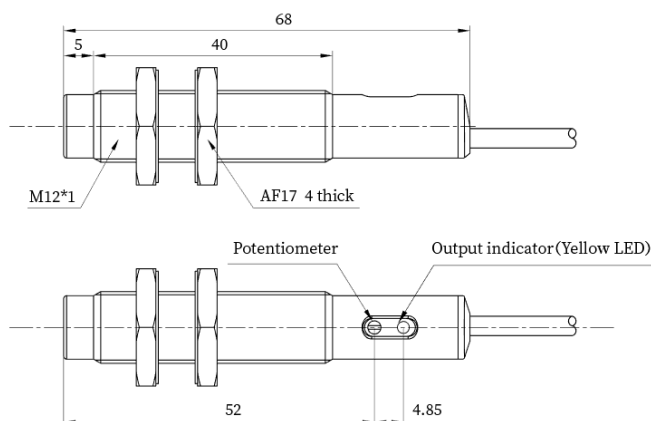

Wiring diagram

