

## Small square photoelectric sensor PSE series



### Features

- ◆ Universal housing, an ideal replacement for a wide range of sensor types
- ◆ IP67, suitable for harsh environments
- ◆ Large knob design, convenient and fast adjustment distance
- ◆ Small detection Blind zone, suitable for the detection of high light objects



### Part number

Cable		Connector	
NPN NO/NC	PSE-YC35DNBR	NPN NO/NC	PSE-YC35DNBR-E3
PNP NO/NC	PSE-YC35DPBR	PNP NO/NC	PSE-YC35DPBR-E3

### Technical specifications

Detection method	Background suppression	Circuit protection	Short circuit, Reverse polarity, Overload, Zener protection
Detection distance <sup>①</sup>	0.2...35cm	Indicator	Green: Power indicator; Yellow: Output, overload or short circuit
Distance adjustment	5-turn knob adjustment	Anti-ambient light	Sunlight interference ≤ 10,000 lux; Anti-incandescent light interference ≤ 3,000 lux
NO/NC Switch	The black wire connected to the positive electrode or floating is NO, and the white wire connected to the negative electrode is NC	Ambient temperature	-25°C...55°C
Light source	Red (630nm)	Storage temperature	-25°C...70°C
Light spot size	Φ6mm@25cm	Protection degree	IP67
Supply voltage	10...30 VDC	Certification	CE
Return difference	<5%	Material	PC+ABS
Consumption current	≤20mA	Lens	PMMA
Load current	≤100mA	Weight	Cable: about 50g; Connector: about 10g
Voltage drop	<1V	Connection	Cable: 2m PVC cable; Connector: M8 4-pins connector
Response time	3.5ms	Accessories	M3 screw×2, Mounting bracket ZJP-8, Operation manual

Note: ①The standard detection target is a white card of 20cm\*20cm (90% reflectivity)

### Dimensions

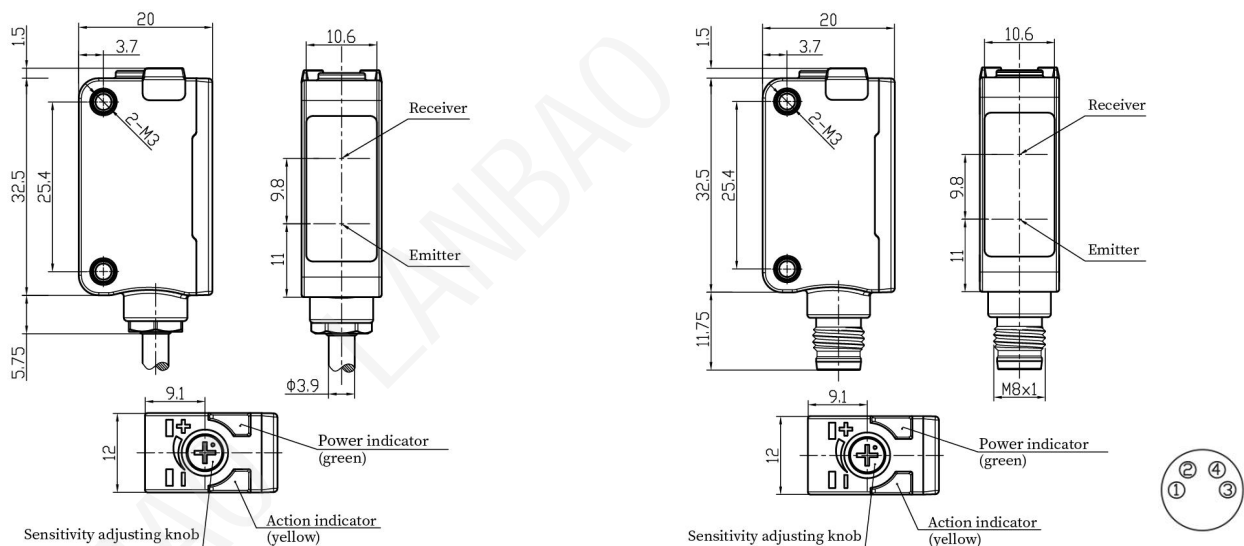

Wiring diagram

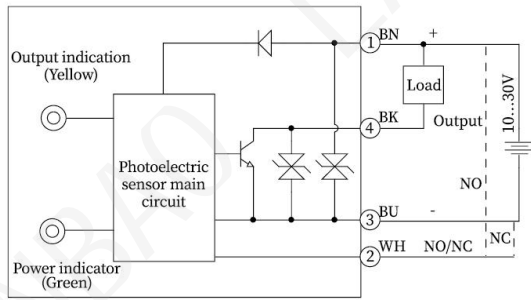

NPN

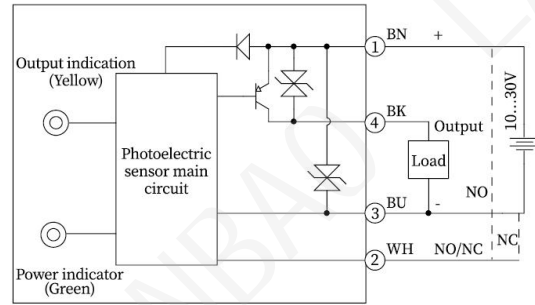

PNP