

Miniature photoelectric sensor PST series



Feature description

- M3 threaded cylindrical installation, small size, easy to install and use
- With 360° visible bright LED status indicator
- Good anti-light interference, high product stability
- Red dot light source design, bright spot, easy to align
- Good background suppression and color sensitivity, stable detection of black objects



Model specification

NPN NO	PST-YC10DNOR	PNP NO	PST-YC10DPOR
NPN NC	PST-YC10DNCR	PNP NC	PST-YC10DPCR

Specifications

Detection distance	10cm*	Light source	Red light(640nm)
Detection of test	1.5...12cm	Response time	T-on:<5ms;T-off:<5ms
Dead zone	<1.5cm*	Indicator	Green: Power Indicator
Standard target	100*100mm white card		Yellow: Output indication
Smallest detector	Φ3mm	Anti ambient light	Sunshine interference≤10,000 lux;
Distance adjustment	knob		Incandescent light interference ≤3,000 lux
Light spot size	8mm@100mm	Operating temperature	-20...55 °C
Color sensitivity	80%	Storage temperature	-30...70 °C
Hysteresis	<20%	Protection degree	IP65
Supply voltage	10...30VDC	In conformity with standards	CE
Consumption current	≤15mA	Housing material	ABS
Load current	≤50mA	Lens	PMMA
Voltage drop	≤1.5V	Connection	2m PVC cable
Circuit protection	Short circuit protection, overload protection, reverse polarity protection	Accessories	M3 Screws(length16mm)、Nut×2、 Operation manual

Remark: *This is data measuring from 100mm*100mm 90% white card.

*The blind area is <1.5cm in the full range, and <0.5cm when the setting distance is <30mm.

Dimensions

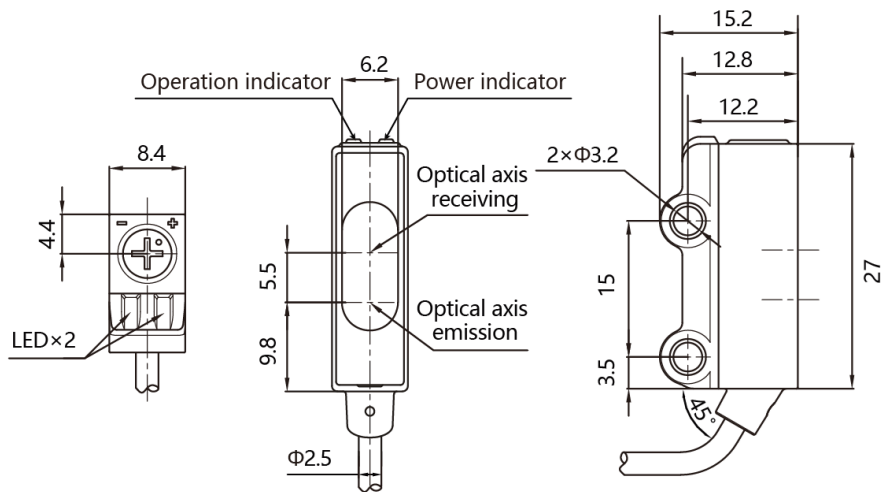

Wiring diagram

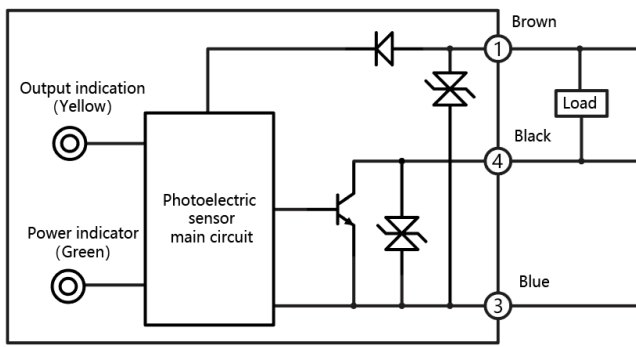

NPN

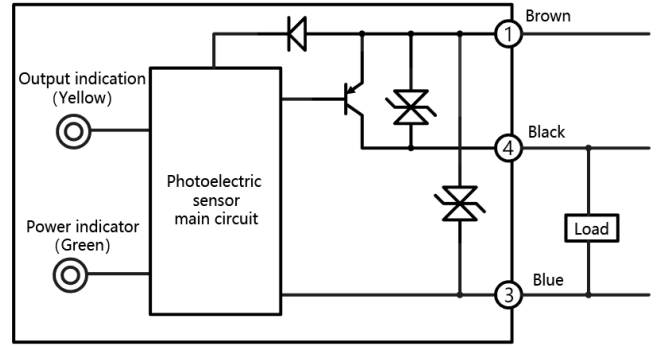

PNP